



SEIKO

FLAT BED MACHINES

LUBRICATION (USE WHITE SPINDLE OIL)

1. To fill oil reservoir on top of machine until oil level reaches to upper reference line A. Always keep oil level is above lower reference line B. (Fig.1)
2. Oiling for hook mechanism: Open slide plate on bed and pull out oil gauge. Fill oil into reservoir for hook mechanism up to level reference mark on the gauge. (Fig. 3)
3. When starting the machine initially and after kept away for a long time without using at all, oil sufficiently to respective necessary parts indicated by arrow before starting operation and pre-running. (Fig. 2, 4 and 5)

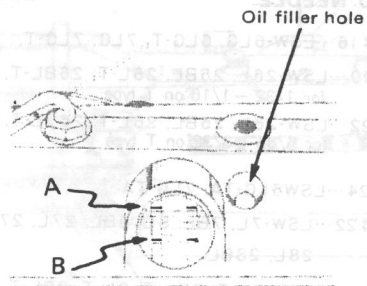

Fig. 1

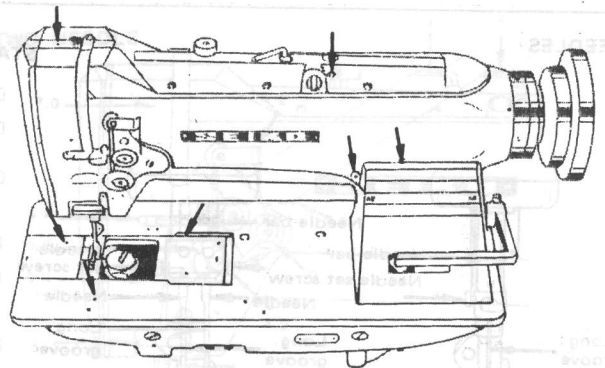

Fig. 2

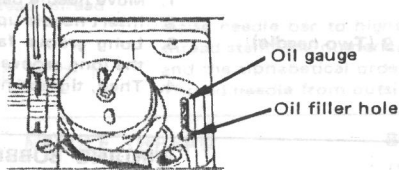

Fig. 3

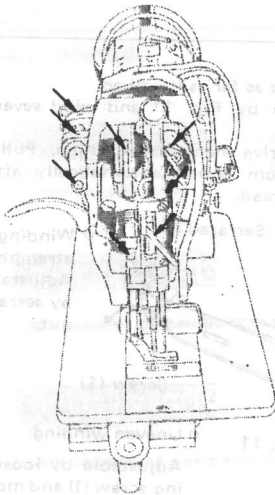

Fig. 4

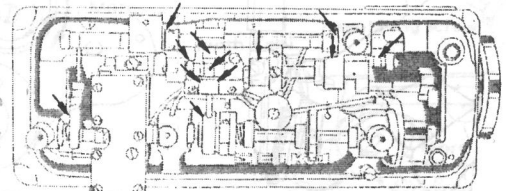

Fig. 5

BOBBIN REMOVAL AND REPLACEMENT STANDARD TYPE

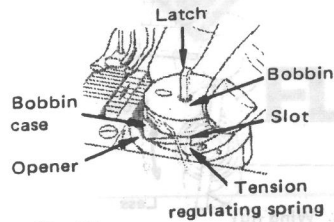

Fig. 12

1. **BOBBIN REMOVAL**
Pull up latch, and bobbin comes up.
2. **BOBBIN REPLACEMENT**
Place threaded bobbin into case and press down the latch. At this time, make sure the bobbin turns to left (counter-clockwise), pulling the thread.

3. THREADING BOBBIN

Guide thread into slot and pull the thread between bobbin case and opener, and pass thread inside of tension spring. Leave about 5 cm from needle plate and close slide plate lightly.

WITH CAP

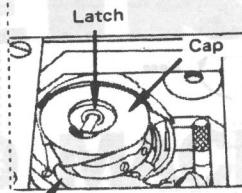

Fig. 13

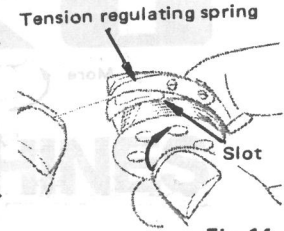

Fig. 14

1. BOBBIN REMOVAL

Pull up latch and remove cap and bobbin.

2. BOBBIN REPLACEMENT AND THREADING

Place threaded bobbin into cap. At this time, make sure bobbin turns to right (clockwise). Then, pull out a length of about 5 cm of thread, guide the thread into slot and pull the thread to left, under tension spring. Place the cap with bobbin into hook and press down the latch.

THREADING NEEDLE ONE NEEDLE

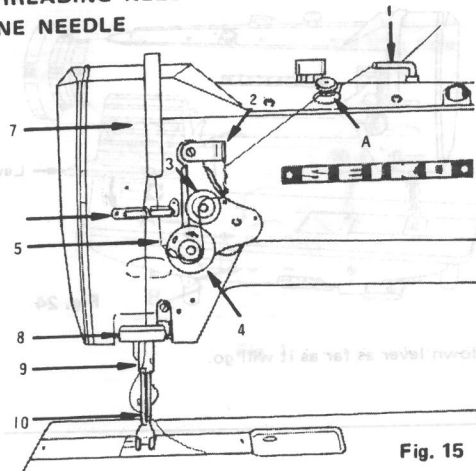

Fig. 15

- Raise needle bar to highest point and lead thread from thread stand the numerical order. Thread needle from left to right.
- A (pre-tension disc) is only for LSW-6LG, 7LG, T, TA type.

TWO NEEDLE

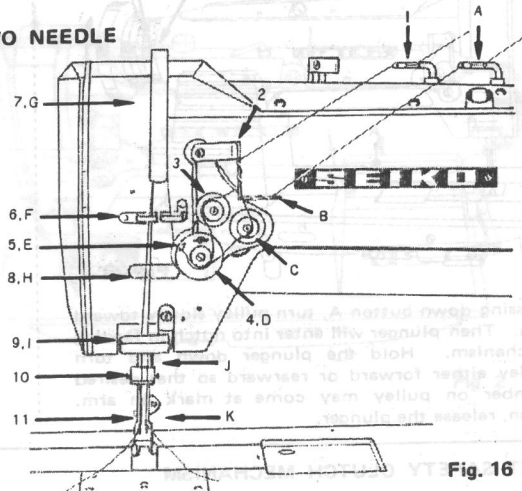

Fig. 16

- Raise needle bar to highest point and lead thread from thread stand the numerical order (1 ~ 11 for left needle) and the alphabetical order (A ~ K for right needle). Thread needle from outside to inside.

THREAD TENSION

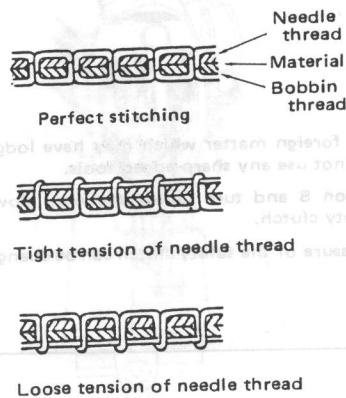

Fig. 17

NEEDLE THREAD

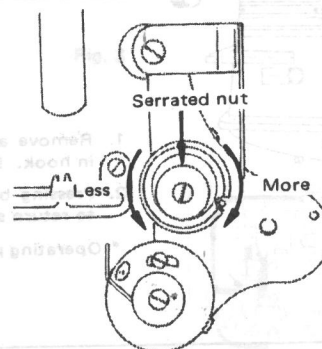
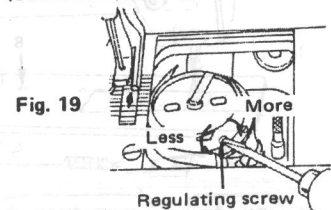

Fig. 18

To adjust, turn serrated nut

BOBBIN THREAD

(Standard type)



(with Cap)

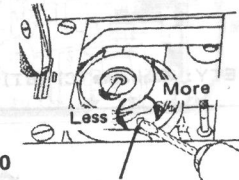
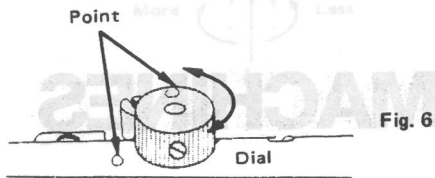

Fig. 20

To adjust, turn adjusting screw

OILING ADJUSTMENT FOR UPPER PART (Fig. 6)



While operating machine, lubrication to each spots of upper part of machine are made automatically. When the machine is in continuous operation, stop oiling for a while at your option. In that case, turn dial until two points fit together, then the dial comes down and the lubrications are stopped.

OILING ADJUSTMENT FOR HOOK MECHANISM (Fig. 7)

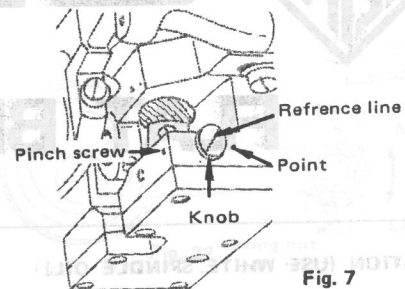

The maximum oil flow is available when reference line on oil adjusting knob is in a line with point on hook saddle. While it stops when the reference line is upright. To adjust, loosen pinch screw and turn oil adjusting knob, then tighten the pinch screw after adjustment.

NEEDLES

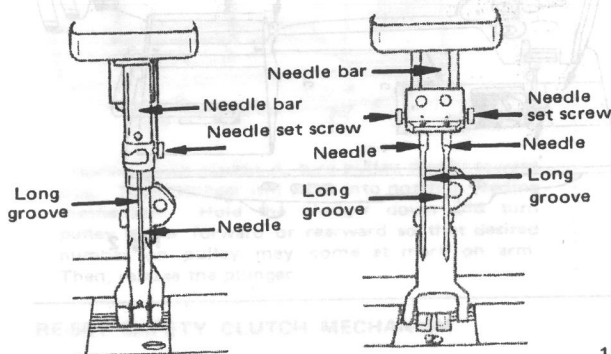

Fig. 8 (One needle)

Fig. 9 (Two needle)

STANDARD NEEDLE

- DP-F22 # 16...LSW-6LG, 6LG-T, 7LG, 7LG-T,
- DPX7 # 19...LSW-26L, 26BL, 26L-T, 26BL-T,
for 1/32" ~ 1/16" on T type
- DPX7 # 22...LSW-26L, 26BL, 26L-T, 26BL-T,
for 5/64" ~ 3/32" on T type
- DPX7 # 24...LSW6LG-TA, 7LG-TA
- DPX17 # 22...LSW-7L, 7BL, 8L, 8BL, 27L, 27BL,
28L, 28BL.
- DPX17 # 24...LSW-7L-T, 7BL-T, 8L-T, 8BL-T,
-27L-T, 27BL-T, 28L-T, 28BL-T.
- DPX17 # 25...LSW-7L-TA, 7BL-TA, 8L-TA, 8BL-TA,
-27L-TA, 27BL-TA, 28L-TA, 28BL-TA

1. Move needle bar to highest point.
2. Insert needle up as far as possible.
3. Long groove faces left (In case two needle machine, the long groove faces inside).
4. Then, tighten needle set screw.

ROLLER PRESSER FOOT (Fig. 10)

(LSW-6LG, 6LG-T, 6LG-TA, 7LG, 7LG-T, 7LG-TA)
26L, 26BL, 26L-T, 26BL-T type

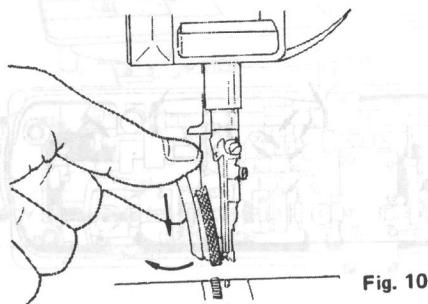

Fig. 10

Lift up presser bar lifter, and press down presser foot saddle and turn it to left. To return, turn it to right.

WINDING BOBBIN

1. Place bobbin on spindle as far as it will go.
2. Lead thread as shown by Fig. 11 and wind several times on bobbin.
3. Press down lever for drive then start machine. Pulley will be disengaged from V-belt automatically after bobbin fills up with thread.

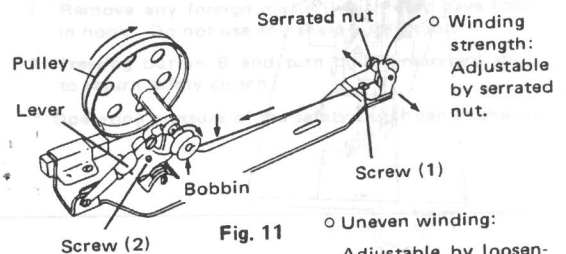

Fig. 11

- Winding amount:
Adjustable by screw (2)
- Winding strength:
Adjustable by serrated nut.
- Uneven winding:
Adjustable by loosening screw (1) and move winder to right or to left.

TO REGULATE PRESSER FOOT PRESSURE

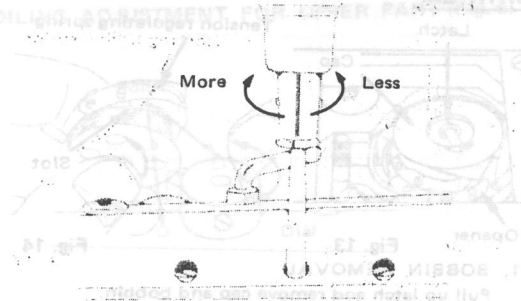

Fig. 21

The pressure on the material should be as light as possible, while still sufficient to insure correct feeding.

ADJUSTING LIFT OF ALTERNATING PRESSER FEET

(Compound feed mechanism only)

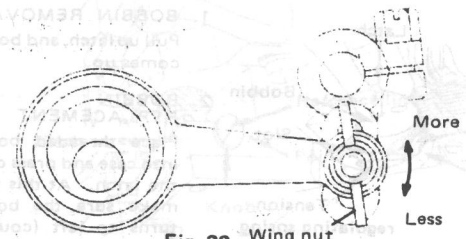

Fig. 22 Wing nut

To adjust, Loosen wing nut and move link and stud assembly along slot.

ADJUSTING STITCH LENGTH

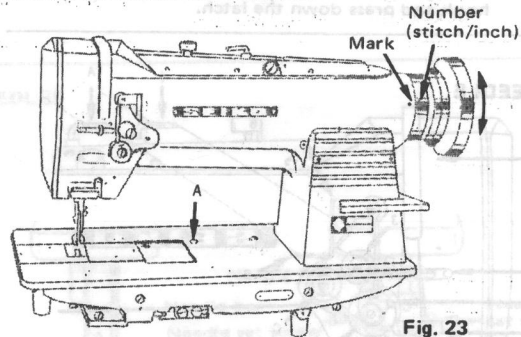

Fig. 23

Pressing down button A, turn pulley slowly toward you. Then plunger will enter into notch in feeding mechanism. Hold the plunger down and turn pulley either forward or rearward so that desired number on pulley may come at mark on arm. Then, release the plunger.

REVERSE STITCHING

(only with reverse mechanism)

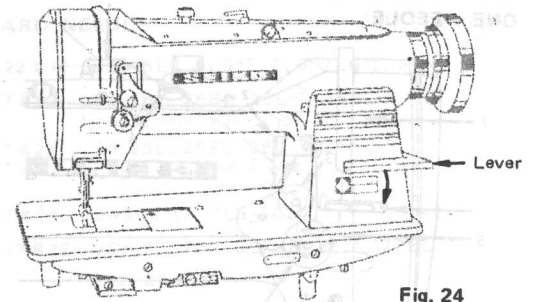

Fig. 24

Press down lever as far as it will go.

RE-SET SAFETY CLUTCH MECHANISM

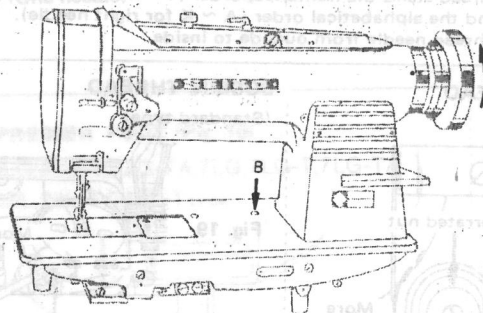

Fig. 25

1. Remove any foreign matter which may have lodged in hook. Do not use any sharp-edged tools.
2. Pressing button B and turn pulley rearward slowly to return safety clutch.

* Operating pressure of the safety clutch can be changed.

VARIETY: Available (C)•(BT)•(FL)



SEIKO SEWING MACHINE CO., LTD.

11-3, Imado 1-chome, Taito-ku, Tokyo, 111 Japan.
Tel.: (03) 872-6171~7,7288 Telex: 2657148 SEIKO J
Cable Address: "SEIKOSEWMCO" TOKYO